

Lamps	Metal halide 4 x 1,000 W
Generator	Brushless 60 Hz, 6.0 kW
Engine	Kubota diesel 13.6 hp
Receptacles	One GFI duplex 20 A / 120 V One T/L 30 A / 240 V
Fuel capacity	30 gal (114 L)
Wheel size	13" (33 cm)
Axle rating	2,000 lbs (907 kg)
Tongue weight travel position	199 lbs (91 kg)
Total weight no fuel	1,725 lbs (783 kg)

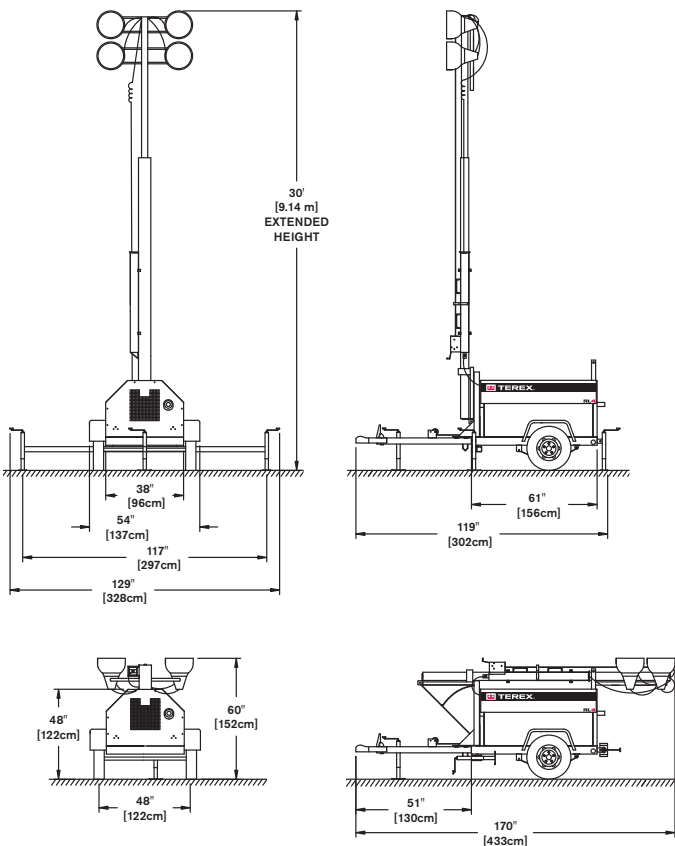

Notice: Metal halide lamp bulbs contain mercury (Hg). Dispose of lamp bulbs according to local, state and federal laws.

## FEATURES

4 X 1000 W Metal Halide lights with Kubota engine and 6kW generator which provides quiet 71 dBA at 23 feet and fuel efficient 60 hour run time.

Durable 30' fully galvanized mast with dual self-braking winch design, 359 degree rotation, and retractable mast cable gives excellent illumination at long distances.

Standard engine protection includes high water temperature and low oil auto shutdowns.

Quick disconnect lights and ballasts allow for easy troubleshooting, service, and repair.

Standard DOT approved run, stop and turn lights

Compact design allows up to 10 units per truck while single point lifting eye and forklift pockets provide for easy loading and unloading



## CHASSIS OPTIONS

Blue paint with Genie Branding	Hitch, 2 1/2 in. ring
Dome light with switch, 12V	Hitch, 2 5/16 in. ball
Export racking and preparation	Hitch, combination ring and ball
Highway safety chains with snap hook	Spare tire and wheel

## ENGINE OPTIONS

6 kW, 60 Hz generator with 15.3 hp Perkins diesel
7 kW, 50 Hz generator with 13.6 hp Kubota diesel
Fuel/water separator filter
Fuel/water separator with fuel line heater

## TOWER OPTIONS

4 horizontally mounted lights, cast aluminum square housing
---

## COLD WEATHER OPTIONS

700 CCA battery	Engine block heater
Battery heater blanket	Low temperature coolant mixture (-40° F)